

SL22-MH THRU SL24-MH

Silicon epitaxial planer type

Features

- Plastic package has Underwriters Laboratory Flammability Classification 94V-O Utilizing Flame Retardant Epoxy Molding Compound.
- For surface mounted applications.
- Exceeds environmental standards of ML-S-19500 / 228
- Low leakage current

Mechanical data

Case : Moulded plastic, JEDEC SOD-123H
 Terminals : Solder plated, solderable per MIL-STD-750, Method 2026
 Polarity : Indicated by cathode band
 Mounting Position : Any
 Weight : 0.0393 gram

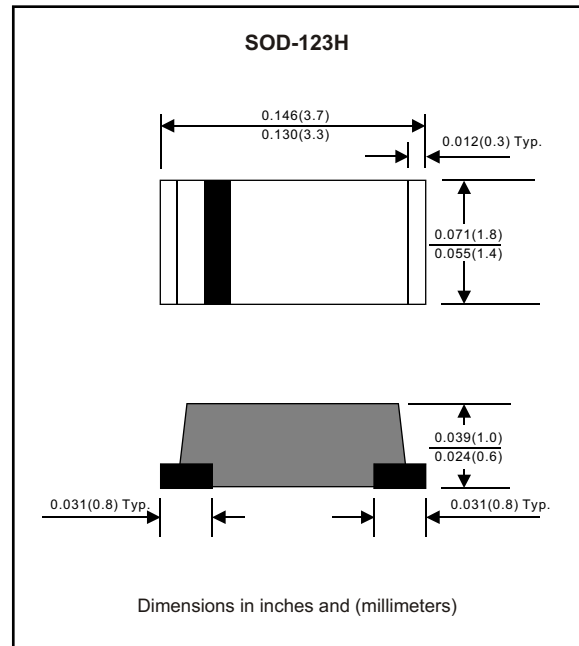

MAXIMUM RATINGS (AT $T_A=25^{\circ}\text{C}$ unless otherwise noted)

PARAMETER	CONDITIONS	Symbol	MIN.	TYP.	MAX.	UNIT
Forward rectified current	See Fig.2	I_O			2.0	A
Forward surge current	8.3ms single half sine-wave superimposed on rate load (JEDEC methode)	I_{FSM}			40	A
Reverse current	$V_R = V_{RRM} \quad T_A = 25^{\circ}\text{C}$	I_R			1.0	mA
	$V_R = V_{RRM} \quad T_A = 100^{\circ}\text{C}$				10	mA
Thermal resistance	Junction to ambient	R_{JA}		70		$^{\circ}\text{C} / \text{w}$
Diode junction capacitance	f=1MHz and applied 4vDC reverse voltage	C_J		160		pF
Storage temperature		T_{STG}	-55		+150	$^{\circ}\text{C}$

SYMBOLS	MARKING CODE	V_{RRM}^{*1} (V)	V_{RMS}^{*2} (V)	V_R^{*3} (V)	V_F^{*4} (V)	Operating temperature ($^{\circ}\text{C}$)
SL22-MH	SL22	20	14	20	0.38	-55 to +125
SL23-MH	SL23	30	21	30	0.40	
SL24-MH	SL24	40	28	40	0.40	

- *1 Repetitive peak reverse voltage
- *2 RMS voltage
- *3 Continuous reverse voltage
- *4 Maximum forward voltage

RATING AND CHARACTERISTIC CURVES (SL22-MH THRU SL24-MH)

FIG.1-TYPICAL FORWARD CHARACTERISTICS

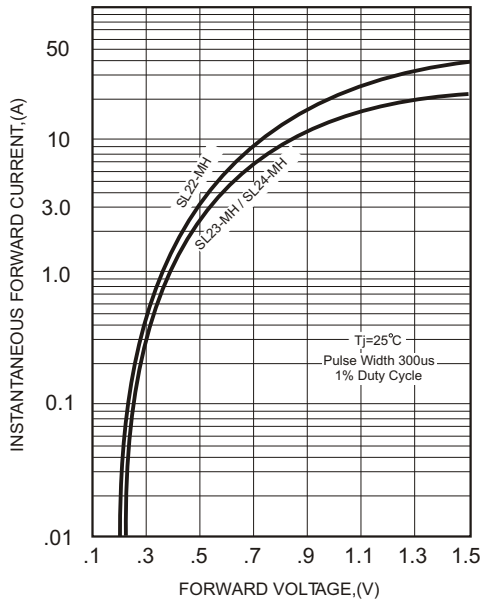

FIG.2-TYPICAL FORWARD CURRENT DERATING CURVE

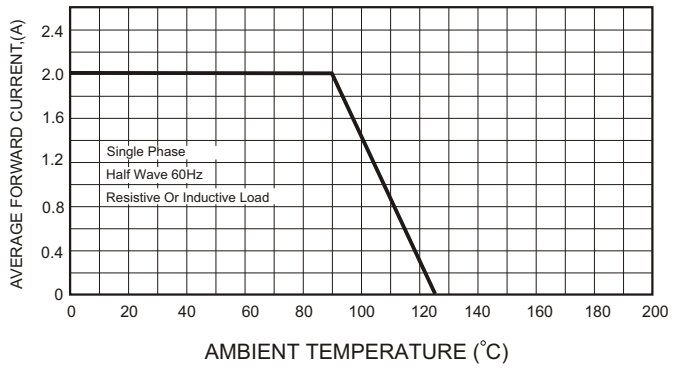

FIG.4-MAXIMUM NON-REPETITIVE FORWARD SURGE CURRENT

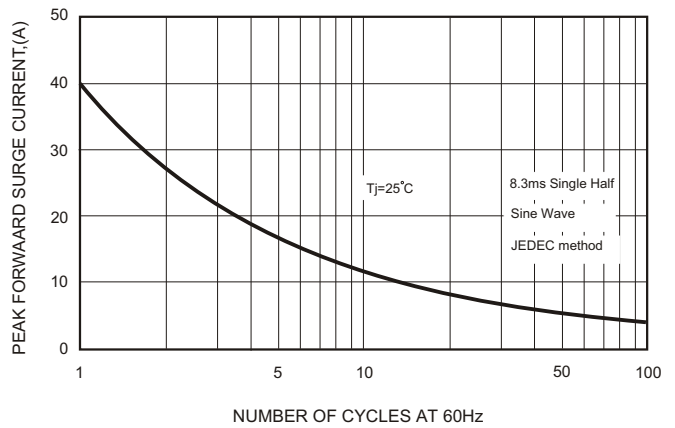

FIG.3 - TYPICAL REVERSE CHARACTERISTICS

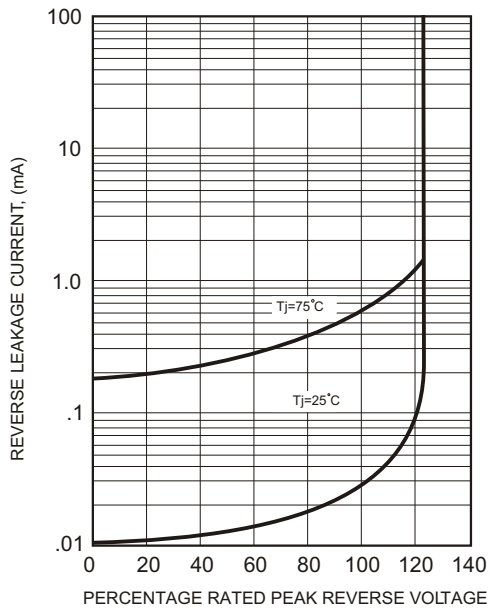

FIG.5-TYPICAL JUNCTION CAPACITANCE

