

MCL4148

Silicon epitaxial planar type

Features

- Low power loss, high efficiency
- High reliability
- High speed ($t_{rr} < 4 \text{ ns}$)

Mechanical data

Case : Glass, Micro-MELF

Terminals : Solder plated, solderable per ML-STD-750,
Method 2026

Polarity: Indicated by cathode band

Mounting Position : Any

Weight : 0.05 gram

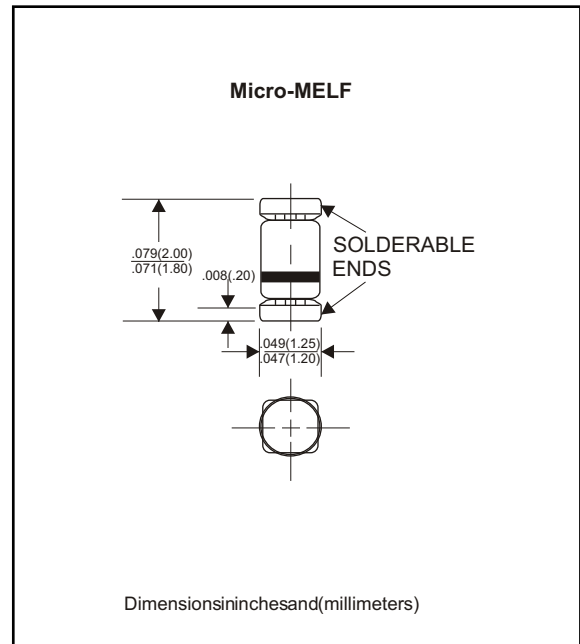

MAXIMUM RATINGS (AT $T_A=25^\circ\text{C}$ unless otherwise noted)

PARAMETER	CONDITIONS	Symbol	MIN.	TYP.	MAX.	UNIT
Non-Repetitive peak reverse voltage		V_{RM}			100	V
Reverse voltage		V_R			75	V
Peak forward surge current	$t_p = 1 \text{ us}$	I_{FSM}			0.5	A
Repetitive peak forward voltage		I_{FRM}			500	mA
Forward current		I_F			300	mA
Average forward current	$V_R = 0$	I_{FAV}			150	mA
Power dissipation		P_V			500	mW
Junction temperature		T_j			125	$^\circ\text{C}$
Storage temperature		T_{STG}	-55		+125	$^\circ\text{C}$

ELECTRICAL CHARACTERISTICS (AT $T_A=25^\circ\text{C}$ unless otherwise noted)

PARAMETER	CONDITIONS	Symbol	MIN.	TYP.	MAX.	UNIT
Forward voltage	$I_F = 5 \text{ mA}$	V_F	0.62		0.72	V
	$I_F = 10 \text{ mA}$	V_F		0.86	1.00	V
Reverse current	$V_R = 20 \text{ V}$	I_R			25	nA
	$V_R = 20 \text{ V}, T_j = 150 \text{ }^\circ\text{C}$	I_R			50	μA
	$V_R = 75 \text{ V}$	I_R			5.0	μA
Breakdown current	$I_R = 100 \mu\text{A}, T_p/T = 0.01, T_p = 0.3 \text{ ms}$	$V_{(BR)}$	100			V
Diode capacitance	$V_R = 0, f = 1 \text{ MHz}, V_{HF} = 50 \text{ mV}$	C_D			4.0	pF
Rectification efficiency	$V_{HF} = 2 \text{ V}, f = 100 \text{ MHz}$	η_R	45			%
Reverse recovery time	$I_F = I_R = 10 \text{ mA}, I_{RR} = 1 \text{ mA}$	t_{rr}			8	ns
	$I_F = 10 \text{ mA}, V_R = 6 \text{ V}, I_{RR} = 0.1 \times I_R, R_L = 100 \text{ OHM}$	t_{rr}			4	ns

RATING AND CHARACTERISTIC CURVES (MCL4148)

FIG.1-TYPICAL FORWARD CHARACTERISTICS

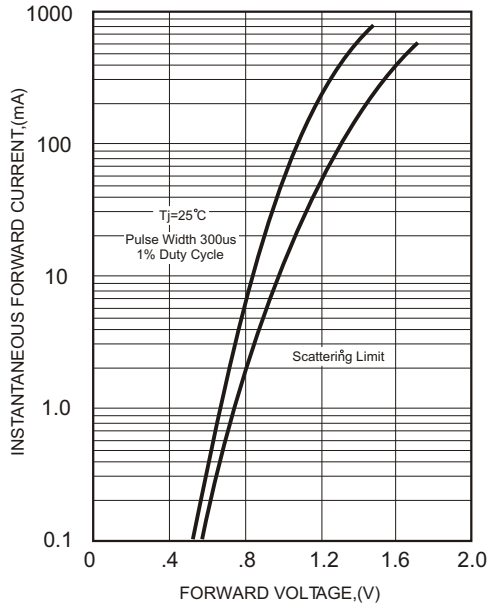

FIG.3 - TYPICAL REVERSE CHARACTERISTICS

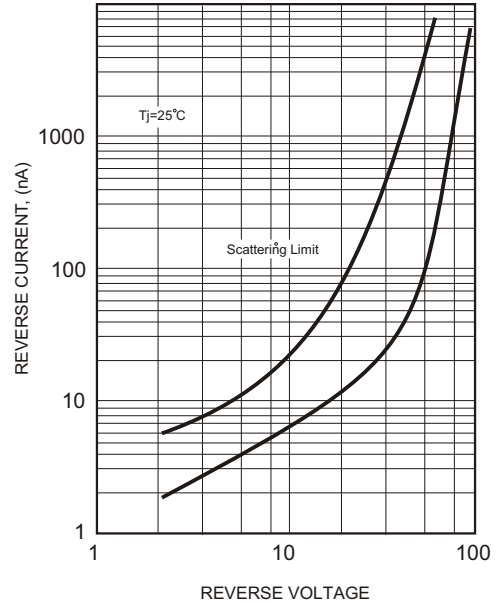

FIG.2 - TYPICAL DIODE CAPACITANCE

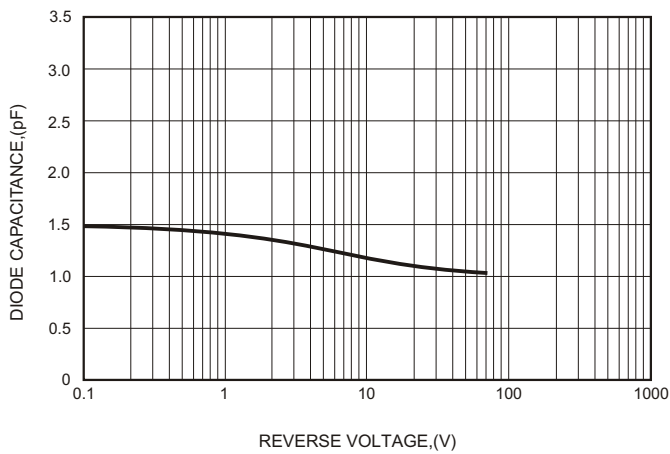

FIG.4 - REVERSE CURRENT VS JUNCTION TEMPERATURE

