

FM4001-MH THRU FM4007-MH

Glass passivated type

Features

- Plastic package has Underwriters Laboratory Flammability Classification 94V-O Utilizing Flame Retardant Epoxy Molding Compound.
- For surface mounted applications.
- Exceeds environmental standards of ML-S-19500 / 228
- Low leakage current

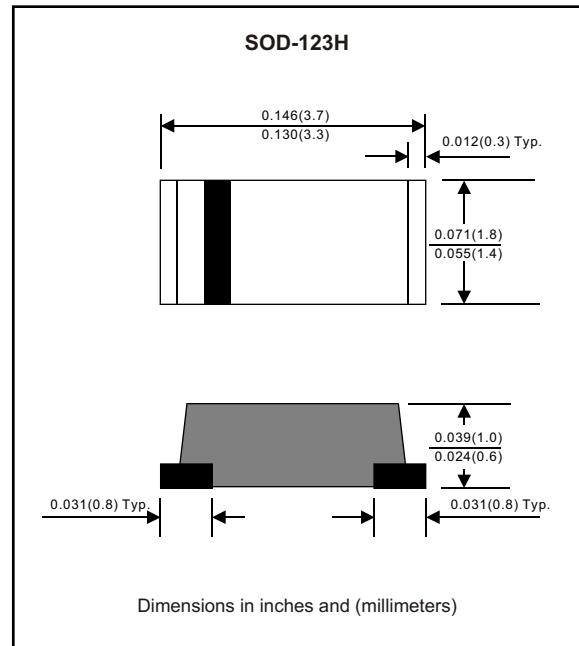

Mechanical data

Case : Molded plastic, JEDEC SOD-123H

Terminals : Solder plated, solderable per MIL-STD-750, Method 2026

Polarity : Indicated by cathode band

Mounting Position : Any

Weight : 0.0393 gram

MAXIMUM RATINGS (AT $T_A=25^{\circ}\text{C}$ unless otherwise noted)

PARAMETER	CONDITIONS	Symbol	MIN.	TYP.	MAX.	UNIT
Forward rectified current	See Fig.2	I_O			1.0	A
Forward surge current	8.3ms single half sine-wave superimposed on rate load (JEDEC methode)	I_{FSM}			25	A
Reverse current	$V_R = V_{RRM} \quad T_A = 25^{\circ}\text{C}$	I_R			5.0	μA
	$V_R = V_{RRM} \quad T_A = 100^{\circ}\text{C}$				50	μA
Thermal resistance	Junction to ambient	R_{JA}		60		$^{\circ}\text{C} / \text{w}$
Diode junction capacitance	f=1MHz and applied 4vDC reverse voltage	C_J		15		pF
Storage temperature		T_{STG}	-55		+150	$^{\circ}\text{C}$

SYMBOLS	MARKING CODE	V_{RRM}^{*1} (V)	V_{RMS}^{*2} (V)	V_R^{*3} (V)	V_F^{*4} (V)	Operating temperature ($^{\circ}\text{C}$)
FM4001-MH	A1	50	35	50	1.1	-55 to +150
FM4002-MH	A2	100	70	100		
FM4003-MH	A3	200	140	200		
FM4004-MH	A4	400	280	400		
FM4005-MH	A5	600	420	600		
FM4006-MH	A6	800	560	800		
FM4007-MH	A7	1000	700	1000		

*1 Repetitive peak reverse voltage

*2 RMS voltage

*3 Continuous reverse voltage

*4 Maximum forward voltage

RATING AND CHARACTERISTIC CURVES (FM4001-MH THRU FM4007-MH)

FIG.1-TYPICAL FORWARD CHARACTERISTICS

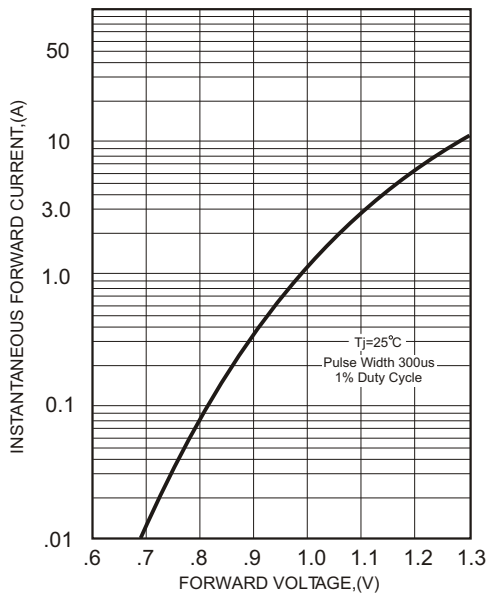

FIG.2-TYPICAL FORWARD CURRENT DERATING CURVE

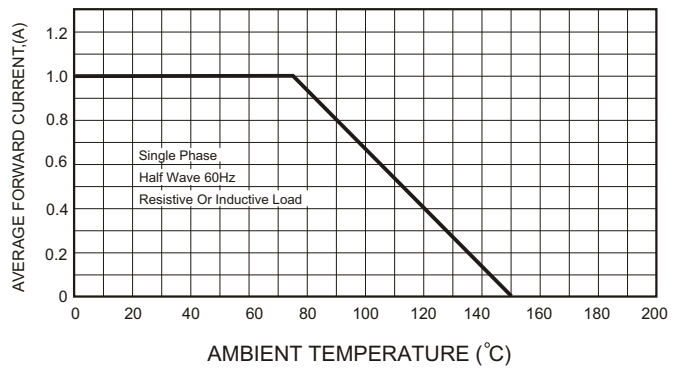

FIG.4-MAXIMUM NON-REPETITIVE FORWARD SURGE CURRENT

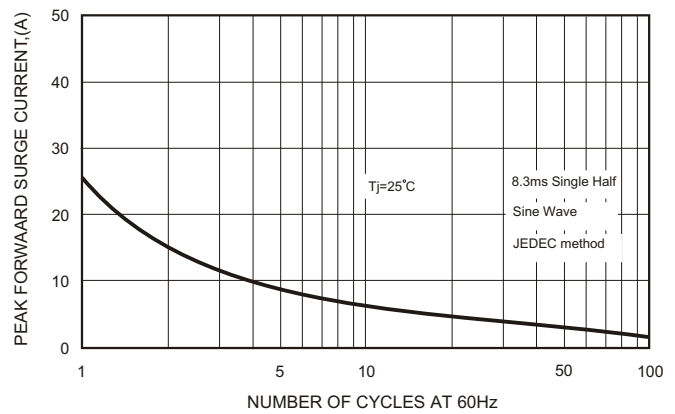

FIG.3 - TYPICAL REVERSE CHARACTERISTICS

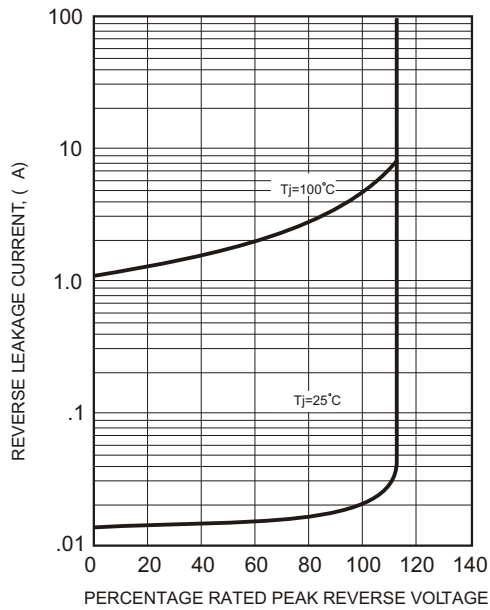

FIG.5-TYPICAL JUNCTION CAPACITANCE

